



## ANALYSIS OF OIL EXTRACTION METHODS FROM FLAX SEEDS

Narziyev M.S.

Candidate of technical science, docent,  
Bukhara Engineering-Technological Institute,  
Bukhara city Uzbekistan,  
E-mail: m\_narziyev@mail.ru

Ismatova N.N.

Postgraduate student, Bukhara Engineering and  
Technology Institute, Bukhara city Uzbekistan,  
E-mail: ismatova.nafisa@inbox.ru  
<https://doi.org/10.5281/zenodo.7840447>

**Abstract.** Flax was grown as an industrial crop in ancient times (about 9,000 years ago in India, 6,000-7,000 years ago in Southern Mesopotamia, 5,000 years ago in Babylon, Egypt) for the production of textiles, as well as food and vegetable raw materials. Culture was brought to Europe from Egypt. Currently, flax is planted on more than 5 million hectares of cultivated land, and  $\frac{3}{4}$  of the world's reserves are oil varieties. At present, the most common methods to extract flaxseed oil are mechanical pressing and solvent extraction. Fresh unrefined oil from pressing flaxseed has a nutty flavor and the color varying from yellow to orange. Flaxseed used for the extraction of oil has various health benefits as the risks of various chronic diseases are reduced. Flaxseed oil has gained a great importance because of its edible oil, which is considered to contain fantastic source of omega-3 fatty acid Alpha Linolenic Acid, proteins, lignans, minerals, vitamins etc. Because of its omega-3 fatty acid content it is used to reduce the risk of various heart diseases. Three-phase partitioning is an efficient bio separation method used for oil extraction from flaxseeds. In this process three phases are formed [1,2]. These phases are organic phase, intermediate and aqueous phase.

**Key words:** linseed, pressing, electric impulse field, oil quality

**Introduction.** Flax is widely used in folk medicine. Flax seeds are of particular importance. Hippocrates himself recommended the use of flax seed infusion as an anti-inflammatory agent for diseases of the respiratory organs and gastrointestinal tract. Flaxseed oil is a valuable source of Omega-3. 30-48% of flax seeds consist of oils: linolenic, linoleic, oleic, stearic, palmitic. Flax contains organic acids, enzymes, vitamin A. Flax also contains proteins and carbohydrates. Canadian scientists have found a connection between breast cancer and flaxseed. It has been found that the daily use of seeds in breast cancer patients helped to stop the growth of the tumor.

To create a single base of scientific research on the cultivation and processing of medicinal plants in the territories of the republic, to study the advanced scientific developments of foreign countries, to establish cooperation with leading scientific institutions, and to introduce modern technologies and scientific developments to the republic and make effective use of existing opportunities in order to increase its use, 2020 the president of the republic of Uzbekistan "on measures on expanding the scope of scientific research on the cultivation and processing of medicinal plants, the development of their seeding" signed the decision. Great attention was paid to the cultivation and processing of flax in the republic.

Currently, 2 types of flax are grown in Uzbekistan, Bahorikor and Bakhmalsky. The Bahorikor variety of flax has thin lanceolate leaves, blue, purple flowers, five petals, round fruit with five cells, 35-50 pods per bush. The average weight of 1000 grains is 4.8 g [3,4]. The average number of grains in one basket is 14. The fat content of grain is 40.8%. The variety is resistant to lodging and shedding, 5.0 points. The average yield is 7.5 s/h. In the territory of our country. It is recommended for people in Kashkadarya and Surkhandarya regions.

In 2022, the areas where oilseeds were planted per thousand hectares are presented in Table 1.

<b>All over the world</b>	3592.65	Mexico	0.005
<b>All in Europe</b>	600,211	Nepal	57,000
<b>According to individual countries</b>		The Netherlands	5.00
Austria	5.00	New Zealand	0.6
Argentina	100,000	Pakistan	8.9
Afghanistan	51.00	Poland	4.89
Bangi	69.20	Russian Federation	70,500
Belarus	78.25	Romania	3
Belgium	9.00	Slovakia	0.4
Bulgaria	0.06	Great Britain	107.07
Brazil	19.21	USA	145,180
Hungary	0.3	Tunisia	2.5
Germany	115.04	Turkey	0.5
Egypt	18.00	Uzbekistan	5.05
India	950.45	Ukraine	27.00
Iraq	0.6	Uruguay	2.7
Iran	0.9	France	45.00
Spain	93.05	Croatia	0.025
Italy	1.05	Czechia	2.05
Kazakhstan	53.00	Chile	1.5
Canada	850,200	Switzerland	14.06
Kenya	0.98	Ecuador	0.078
China	630.00	Eritrea	3,002

Linseed oil is one of the most widely used technical and medicinal products. Data on the production and export of edible vegetable oils in different countries in the first half of the 21st century can be found in Table 2 shows.

Countries	2021	2022
England	90	85
Italy	27	9
Netherlands	95	40
USA	270	350
France	88	90
Sweden	20	21



Linseed oil is of great technical importance: quick-drying varnishes, drying oils, liquid driers are made from it. It is widely used for the production of natural linoleum and oil paints used in painting. Flaxseed oil is consumed (the content of unsaturated fatty acids in it is 2 times higher than fish oil) and internally in medicine (its use reduces the risk of stroke by 37%) and in the form of ointments and rubs is used [5].

In Table 3, Flax seed ( Bahorikor variety) the content of nutrients (calories, proteins, fats, carbohydrates, vitamins and minerals) per 100 grams of the consumed portion is indicated.

Nourishing	Amount	Norm	% of norm in 100 g	% of norm per 100 kcal	100% is the norm
calories	890 kcal	1683 kcal	54.4 %	5.8%	187%
fat	99.9g	58 g	180.1%	18.8%	55%
Water	0.1 g	2271 g			1126200g
Vitamins					
Vitamin B4	2.2mg	14 mg	14%	1.6%	714
Vitamin E alpha tantherol TE	9.1 µg	121 µg	7.6%	0.8%	1290
Macroelements					
Zinc Zn	0.07 mg	12 mg	0.6%	0.1%	17143 g
Saturated fatty acids					
Saturated fatty acids	9.6 g	maximum 18.7 g			
Monounsaturated fatty acids	18,438 g	min 16.8 g	109.8%	12.2%	
Polyunsaturated fatty acids	67.7 g	From 11.2	20.6 g	328.6%	36.6%
Omega 3 fatty acids	53,368 g	From 0.9 to 3.7 g	1442.4%	160.6%	
Omega-6 fatty acids	14.292 g	From 4.7 to 16.8 g	100%	11.1%	

Flaxseed oil is a fast-drying oil because it easily polymerizes ("curses") in the presence of atmospheric oxygen. This ability is due to the high content of unsaturated fatty acids:

15%-30% - linoleic acid;

44%-61% - linolenic acid;

13% - 29% - oleic acid;

According to the method of obtaining vegetable oils, they are divided into two types: pressed and extracted. The method of pressing is that oil plants cleaned from rough shells are crushed and pressed under high pressure in continuous hydraulic and screw presses [6].



1. With the hot pressing method, the raw material is placed in a press extruder designed to simultaneously grind and heat the raw material up to 120°C, the mass is continuously compressed and divided into vegetable oil and cake. It is more intense color, as well as a specific taste and smell.

## 2. Cold pressing.

In cold pressing, crushed seeds are pressed without heat treatment, allowing to obtain without preheating to 120°C and without requiring treatment with chemical solvents. Stretched and cleaned raw material is placed under the press. With this type of pressing, there is no local heating and burning of raw materials in grills, the resulting oil is of high quality. Oil yield is about 30% of the total mass. Cold-pressed oils preserve the maximum useful components of raw materials. An external sign of cold-pressed oil may be the presence of a cloudy sediment (especially at low temperatures). It should not be used for frying: it foams and burns. Oil with less impurities, more stable during storage, less color, mild taste and smell is obtained. This oil does not last long and is expensive [7,8]. During extraction, the oil is separated from the crushed seeds using various fatty solvents (usually gasoline, sometimes trichlorethylene, carbon tetrachloride, etc.). The solvent has a low boiling point (75-90 degrees), so it is easily separated from the fat and the lean mass of the seeds (meal) by distillation (heating). The solvent then turns into a vapor, which condenses into a liquid as it cools in the coils. The resulting liquid is used to obtain the next batch of seeds.

Oils obtained by extraction are subjected to additional processing (refining), as a result of which pure oil, barely colored, has a light taste and smell. Beneficial components are partially lost in oils obtained by the extraction method - vitamin E, plant styrenes, etc. Extraction achieves almost complete separation of the oil from the oilseed.

Depending on the type of processing, vegetable linseed oil can have the following names:

1. unrefined - purified from mechanical impurities by sedimentation, filtration or centrifugation. Such oil retains all its properties (color, taste, smell), but during long-term storage it deteriorates and gives sediment (fus);
2. hydrated - treated with water to remove phosphatides that precipitate in the oil. This oil retains the properties of unrefined oil and does not get into the mud;
3. refined - mechanical and chemical processing (refining) with alkali, neutralization of free fatty acids. No precipitation in this oil, stable storage; color, taste and smell are weak.
4. cleaned bleached deodorized - in addition to cleaning, it has undergone bleaching and deodorization. Bleaching results from treatment with bleaching earths (clay) followed by filtration through activated carbon to change the color of the oil.

Usually, pressing in linseed oil production plants is carried out in continuous screw presses. With small-scale production (on small farms), pressing is carried out either in simplified screw presses (Fig. 1) or in periodic hydraulic presses.

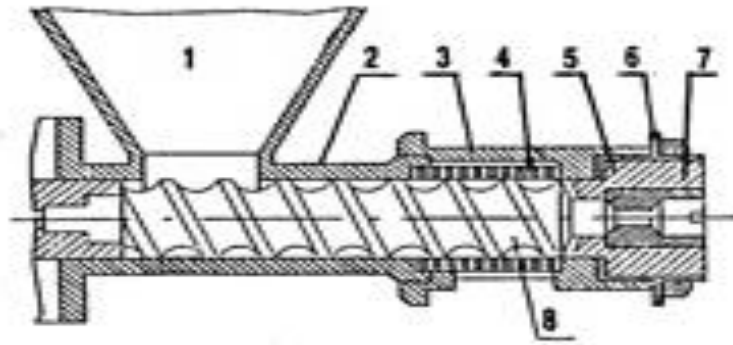

Figure 1. A simplified screw press. 1-funnel body .2-body. 3- press 4- perforated cylinder . 5- sleeve (bubble). 6- lock-nut . 7-filter. 8-screw

In industrial screw presses, the process is carried out in a grid - a cylindrical chamber made of metal strips, between which there are holes for oil to escape. The room has a screw with a variable pitch of turns. The pulp in the chamber is compressed by a screw, and the oil flows out through the slots.

In time-operated hydraulic presses, pulp wrapped in a napkin is pressed between the plates of the press. Oil flows along the edges of the plates. Forming packages, loading and unloading in these cases is done manually. With hydraulic pressing, up to 5% fat remains in the cake. Linseed oil production is complicated by a number of problems. First, the oil can only be pressed from the seeds of plants grown without the use of pesticides or fertilizers containing heavy metals [9]. This increases the labor intensity of cultivation. Secondly, the technology of flax production requires strict adherence to the temperature regime, which harms labor productivity, the use of expensive equipment, etc. It is during the process of chemical reactions, when the distillation unit is heated above 35. alpha-linolenic acid loses its beneficial properties in the presence of oxygen.

**Conclusion.** A long with, studies have shown that currently used technologies for processing linseed allow to obtain technical linseed oil or edible linseed oil with high productivity. The purpose of this work is to justify the most effective methods of increasing the yield of edible linseed oil while maintaining its quality. In this work, the process of preparing flax seeds for pressing is carried out by processing under the influence of an electric impulse field. The subject of the study was the use of samples of high-quality linseed of the Bachmalsky variety, which contained 47% linolenic acid in the fatty acid content of the oil.

The level of linseed oil production is related to the physiological and anatomical properties of the seed tissue. The protoplasm of a living cell does not conduct intracellular extractives well. The main factor determining the yield of linseed oil during pressing is the cell permeability of the plant tissue.

Separation of oil from raw flax depends on the viscosity, elasticity and other properties of the protoplasm. These indicators of protoplasm determine the ability to resist external influences such as preliminary processing of raw materials and its pressing. The greater the disturbance in the protoplasm as a result of the preliminary treatment, the greater will be the release of oil.

It was found in laboratory conditions that cell death can be achieved by treatment with high voltage pulse discharge. During a high-voltage pulsed discharge, an electrohydraulic shock

occurs in the liquid, as a result of which ultrasonic, cavitation and resonance phenomena occur, and a pulsed electromagnetic field appears. The interaction between the field and the force between the system of electrically charged cells has a rapid effect on biological systems. This coagulates protoplasmic protein, cell permeability increases. After such processing, the amount of oil from flax seeds increases by 6-8%.

The use of short electrical pulses for electrical processing of food products is promising, and their effect has a number of advantages over other electrical methods. The concentration of electrical energy and the short-term impulse effect on the processed material will lead to qualitatively new effects that can be the basis for the development of high-performance technological methods.

### References:

- 1.Soliva-Fortuny R., Balasa A., Knorr D., Martin-Belloso O. Effects of pulsed electric fields on bioactive compounds in foods: a review. *Trend Food Sci. Technol.* 2009.20 (11-12), 544-556.
- 2.Shorstkii I., Mirshekarloo M.S., Koshevoi E. Application of pulsed electric field for oil extraction from sunflower seeds: electrical parameters effects on the oil yield, *Food processing technologies*, 2015. DOI: 10.1111/jfpe.12281
- 3.Ismatova Sh.N. Prospects of the use of quinoa and amaranth for expanding of food reserve of poultry farming / Ismatova Sh.N., Isabaev I.B., Ergasheva X.B., Yuldasheva Sh.J.// *Austrian journal of technical and natural sciences*. Austria, No. 7-8. 2020. pp. 26-30
- 4.Ismatova Sh.N. Alternative sources of raw materials for the production of feed products / Ismatova Sh.N., Isabaev I.B., Ergasheva H.B.// *Universum: Technical sciences: scientific journal* 2019. – No. 12(69). – pp.18-23.
- 5.O.R. Abduraxmonov, O.K. Soliyeva, M.S. Mizomov, M.R. Adizova Factors influencing the drying process of fruits and vegetables *ACADEMICIA: "An international Multidisciplinary Research Journal" in India*
- 6.Kh.F.Djuraev , M.S. Mizomov Analyzing Moisture at the Drying Process of Spice Plants - *Texas Journal of Agriculture and Biological Sciences*, 2022
- 7.Sharipov N.Z., Narziyev M.S., Yuldasheva Sh.J., Ismatova N.N., Functional Properties of the Processing Soybeans Products, *Eurasian Research Bulletin*, Volume 12|September, 2022, ISSN: 2795-7365, 50-54 pages, <https://geniusjournals.org/index.php/erb/article/view/2222>
- 8.Kh.F.Djuraev, Yodgorova M., Usmonov A., Mizomov M.S. Experimental study of the extraction process of coniferous plants, *IOP Conf. Series: Earth and Environmental Science* 839 (2021) 042019.
9. Kh. F., Djurayev; M. S., Mizomov; U. D., Ashurova; N. A., Duskarayev; I. O', Oripov Maintaining the quality indicators of the product during low temperature drying of spices and herbs by researching the optimal values of humidity and temperature. *International Journal of Early Childhood Special Education*. 2022, Vol. 14 Issue 7, p1542-1548. 7p.
- 10.Nafasova, D. (2022). TABIIY RESURSLARNI BOSHQARISH, EKOLOGIYA VA ATROF-MUHIT MUHOFAZASI. *Scientific progress*, 3(3), 739-744.
11. Турсунов, X., & Алибаев, М. А. (2020). Важность обеспечения безопасности наземных транспортных средств. *Life Sciences and Agriculture*, (3-2), 33-36.
- 12.Hamdani, T. (2022). Theoretical and Methodological Aspects of Community Supervision Instituting. *American Journal of Economics and Business Management*, 5(9), 80-85.



13. Tursunov, X. T., & Rahimova, T. U. (2006). *Ekologiya*.
14. Турсунов, Х., & Алибаев, М. А. (2020). REQUIREMENTS TO ENSURE THE SAFETY OF GROUND VEHICLES. *Life Sciences and Agriculture*, (3-2), 33-36.
15. Турсунов, Х. КОРХОНАЛАРДА МЕХНАТНИ МУХОФАЗА КИЛИШНИ АСОСИЙ ЧОРА-ТАДБИРЛАРИ ВА УНИ ТАШКИЛ ЭТИШДА КАСАБА УЮШМАЛАРИНИНГ РОЛИ. *Хорийи ҳамкорлар исhtirokida o 'tkazilgan Respublika ilmiy-amaliy anjumani to'plamining TAHRIR XAY'NATI*, 607.
16. Habibullaevna, K. C. ., & Xamdam, T. . (2023). Training of the Population in the Field of Civil Defense and Protection against Emergencies. *Best Journal of Innovation in Science, Research and Development*, 2(3), 17-20.
17. Abdurashid, A. (2023). SANOAT KORXONALARIDA YUK KO 'TARISH MASHINALARINI ISHLATISH TARTIBI VA XAVFSIZ ISHLATISH BO 'YICHA CHORA-TADBIRLAR ISHLAB CHIQUISH. *Journal of new century innovations*, 24(3), 46-50.
18. Abdurashid, A., & qizi Xushvaqtova, V. A. (2023). ISH JOYLARIDAGI JAROHATLANISHLARNI OLDINI OLIH BO 'YICHA XALQARO TAJRIBALAR TAHLILI. *Journal of new century innovations*, 23(3), 173-176.
19. Abduraxmonov, A. A., & Dadabayeva, N. A. (2021). O'TA XAVFLI YUQUMLI KASALLIKLAR VA ULARNING TARQALISHINI OLDINI OLIH CHORA TADBIRLARI. *Academic research in educational sciences*, 2(3), 340-351.
20. Atakhanovich, Abdurakhmonov A., and Dadaboeva N. Abdurazakovna. "Origin And Protection Of Epidemiological And Episoootic Diseases." *JournalNX*, 2021, pp. 744-751.
21. Abdurakhmonov, A. A., & Dadabayeva, N. A. PREVENT SERIOUS INFECTIOUS DISEASES AND THEIR SPREAD PRECAUTIONARY MEASURES.
22. Abdurashid, A. (2023). Energetik innovatsion poligon tashkil etish. *Journal of new century innovations*, 20(1), 169-177.
23. Abdurashid, A. (2023). Qayta tiklanuvchi energetika manbai. *Journal of new century innovations*, 20(1), 178-186.
24. Абдурахмонов А. А., Дадабаева Н. А. ЗАМОНАВИЙ РАҚАМЛИ ТЕХНОЛОГИЯЛАРНИНГ ҚЎЛЛАНИЛИШ СОҲАЛАРИ ВА ЮТУҚЛАРИ //Academic research in educational sciences. – 2021. – Т.
25. Abdurakhmanov, A., & Usmonov, U. (2023, January). THE PROBLEMS OF AUTOMOBILE ENTERPRISE STUDYING MUD SWEATS AND STORING THEM IN A LAND. In *Proceedings of International Conference on Scientific Research in Natural and Social Sciences (Vol. 2, No. 1, pp. 105-108)*.